

ISSPRO R4605-24VDC 24 Volt Pulse Distribution Module Customer Instructions

Introduction:

The R4605-24VDC Pulse Distribution Module has been developed to solve problems caused by attaching multiple instrumentation to one magnetic sensor. This unit provides five (5) totally independent outputs from one standard magnetic sensor. Incorporated into the design are all the parameters outlined in the SAE J1455 Draft, which covers recommended environmental and electrical practices for electronic equipment design in heavy-duty trucks.

Advantages:

Input:	The R4605-24VDC will operate from any standard geartooth sensor or AC signal generator for speedometers or tachometers. Signal conditioning is designed into the circuitry to ensure against false triggering by noise generated in the truck electrical system.
Output:	The five outputs are totally independent from the input and from one another and simulates a zero crossing magnetic sensor. If one or more outputs are shorted to either battery positive or ground, there will be no effect to the operation of the unit or remaining outputs. Also, once a short is removed from a particular output, that output will again function normally. No interaction between outputs will occur. All five outputs adhere to the guidelines established in the SAE J1455 Draft.
Power:	The R4605-24VDC is compatible with all 24 volt, negative ground truck electrical systems. There are no adjustments or calibrations to make. Internal protection guards against damage due to reversing power leads. Internal filtering protects against both voltage transients and electrical noise, inherent to truck electrical systems.
Wiring:	There are seven pairs of wires on the R4605-24VDC Pulse Distribution Module. The yellow/blue pair attach to the magnetic sensor (MS); yellow to the MS signal and blue to the MS common. The red/green pair attach to power; red to the switch side of the ignition switch and green to the battery ground. The remaining five white/black pairs are the five outputs; white to signal positive, and black to output signal common. Connect an instrument to one pair of the output wires. If more than five pieces of equipment require a signal, a second R4605-24VDC may be wired in series. NOTE: If there is an instrument attached to the magnetic sensor, disconnect it from the sender and attach it to one of the outputs of the Pulse Distribution Module.
Compatibility:	At the time of this printing, units have been tested on and found compatible with most truck speedometers and tachometers currently in use.

CAUTION: *The green, blue, and all five black wires are electrically common to one another. Therefore, if battery common (negative) is connected to any of these wires AND battery (positive) is connected to another of these wires, damage to the circuitry will occur.*

Diagram of the R4605 Pulse Distribution Module

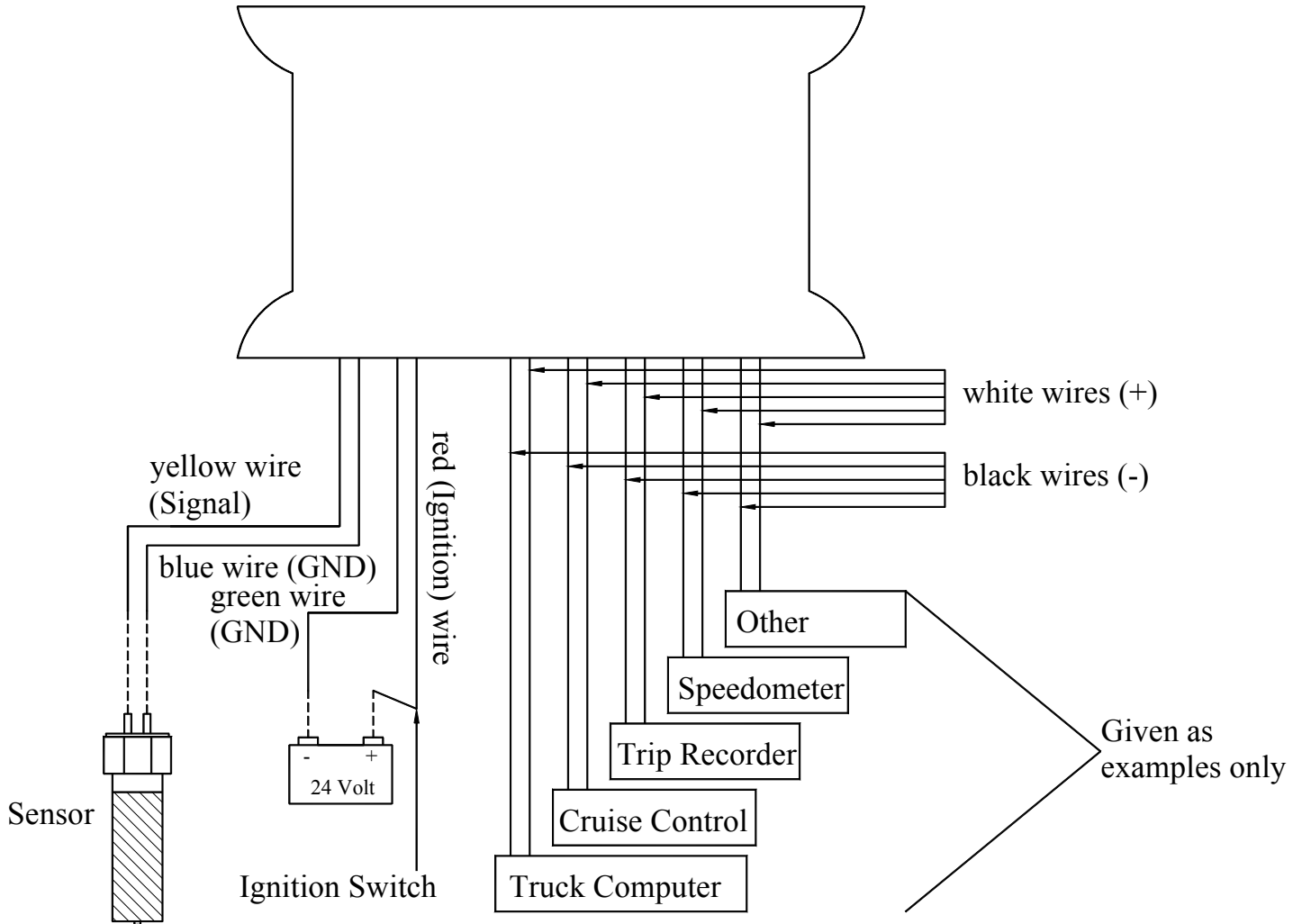

Note: Blue, green, and black wires are internally connected.