



Instr. No. 2650-892D

INSTALLATION INSTRUCTIONS 3 3/4" & 5" ELECTRONIC SPEEDOMETER MODEL 19350, 19351, 19352, 19354, 19355, 19356, 19360, 19361, 19364, 19365



General Information

This electronic speedometer utilizes a LCD to display odometer and trip odometer mileage. Momentary pressing of the button on the dial window toggles the odometer/trip odometer information displayed on the LCD. Pressing and holding the button for more than two seconds while in trip mode will reset the trip odometer. The odometer cannot be reset.

This Auto Meter Electronic Speedometer is pre-calibrated for 16,000 pulses/mile. If the sender on the motorcycle does not issue 16,000 pulses/mile, the speedometer must be recalibrated (see calibration section)

NOTE: After installing and wiring the speedometer correctly it should operate WITHOUT having to be recalibrated. If the sender does not issue 16,000 pulses per mile, the mile per hour reading will be incorrect, but the speedometer should operate. If there is no operation at all before recalibration, there may be a problem wiring or the sender. Check all connections and make sure the speedometer and sender are installed correctly. Once the speedometer is operating, recalibration can then be performed if necessary.

NOTE: With power off, the speedometer pointer may not always rest at zero. This is normal. When power is applied, the pointer will initially move to mid-scale before positioning correctly at 0mph.

NOTE: The odometer on this speedometer may read from 1 to 5 miles. This is done during factory testing to insure maximum quality.

Speedometer Senders

The speedometer is designed to operate with an electrical speed sender. The speed senders signal pulse range must be between 500 and 400,000 pulses/mile. Any speed sender or electronic module that meets the following two conditions can be used:

- Pulse range generated proportional to vehicle speed
- Output within the voltage ranges listed below:
 - 2.0 to 16V peak (Square Wave), 3 wire
 - 2.0 to 120V peak to peak (Sine Wave), 2 wire

Mounting

All 3 3/4" models

These speedometers can be mounted in existing mounts (see dimensions at right) or by using Auto Meter's model 19243 shock strap replacement kit and model 19240 mounting bracket (see bracket instruction below). Different mounting options are also available from third party suppliers. Please see individual manufacturer instructions for mounting your speedometer with their brackets.

Models: 19350, 19351, 19352, 19354, 19355, 19356

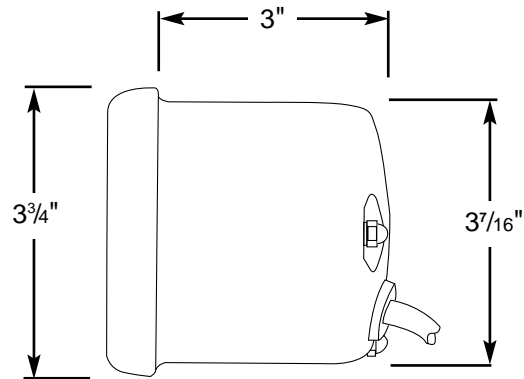

Motorcycle Bracket 19240

Requires Auto Meter replacement shock strap kit 19243

1. Drill holes in speedometer mount to match your mounting holes on your triple tree.
2. Bolt speedometer mounting bracket securely in place.
3. Line up holes on speedometer mount with holes on speedometer mount. Position the 1/4"-20 head screws through mounting bracket and tach base. Tighten with the 1/4"-20 acorn nuts.

Models: 19360, 19361, 19364, 19365

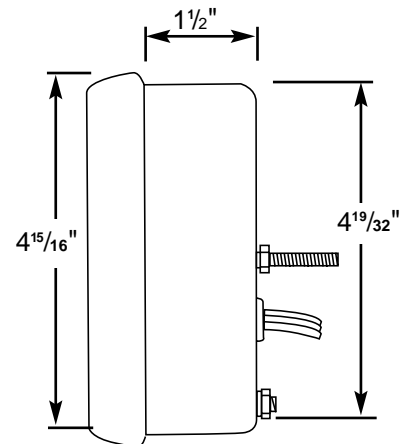

All 5" models

These models are designed to be tank mounted or require custom mounting options. Use the dimensions at right for size requirements. See your local shop or distributor for details.

Calibration

Calibration Range: 500 to 400,000 pulses/mile

1. Speedometer and sender must be installed properly and all wires must be connected correctly.
2. To set the speedometer in calibration mode:
 - a) With power to the speedometer OFF, press and hold the trip/reset button.
 - b) While holding the button, turn power ON to the speedometer (typically this is done by turning the ignition switch to the run position if the speedometer power is connected to the ignition switch)
 - c) Continue to hold the trip/reset button until the pointer moves to full scale.
 - d) Release the trip/reset button.

NOTE: On some aftermarket ignition switches, power to the speedometer may be interrupted while starting the engine if power to the speedometer is connected to the ignition switch. Make sure the power to the speedometer is NOT interrupted while starting engine. If power is interrupted while starting engine, the pointer will move from full scale back down to zero indicating that the speedometer has exited calibration mode and returned to normal operation. In normal operation, new calibration of the speedometer is not possible, and speedometer will retain the original factory calibration. If power is interrupted to the speedometer while starting the engine replace the calibration procedure with the following:

- e) With power to the speedometer OFF, press and hold the trip/reset button.
- f) Start the engine while holding the trip/reset button.

- g) Continue to hold the trip/reset button until pointer moves to full scale.
 - h) Release trip/reset button.
3. Go to the beginning of a known two-mile distance and stop.
 4. Press the Trip/Reset button. The pointer will move to half scale and the speedo is ready to be calibrated.
NOTE: Speedometer accuracy depends on the accuracy of the measured two mile distance.
 5. Drive the two mile distance and stop.
 6. Press and release the Trip/Reset button again. The calibration mode will be exited and the pointer will return to zero. Calibration is complete.

This is a list of factors that can affect speedometer accuracy and how to minimize them during calibration.

1. Tires slightly increase in diameter as vehicle speed increases. To minimize this error ride at an average speed during calibration. (Approximately 45 mph for most street vehicles.)
2. Tires slightly increase in diameter as air pressure is increased. To minimize this error, check the tire to ensure correct air pressure.
3. Tire slippage. Minimize this error by not breaking traction.
4. Accuracy of 2 mile distance driven during calibration. Minimize this error by verifying the distance.

NOTE: Always recalibrate speedo after any tire size or gear ratio change.

Wiring

(Generic)
Back of speedometer

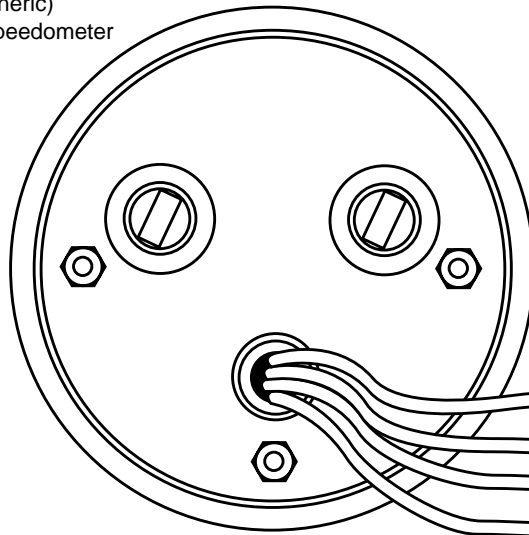

WARNING
Incorrect hookup will damage the speedometer and void warranty. Please read the instructions carefully.

NOTE: Lighting will be on if power is supplied to the speedometer

- Orange, Turn signal cancel module, (Harley-Davidson® applications only).
- Red, +12 volt switched power source
- Black, ground
- Purple, signal wire (to sender)

NOTE: If you are installing this speedometer on a Harley-Davidson® motorcycle that came equipped with a turn signal canceling module, connect the orange wire from the Auto Meter speedometer to the white wire with green stripe (W/GN) that runs from the OEM speedometer to the turn signal canceling module.

SERVICE

For service send your product to Auto Meter in a well packed shipping carton. Please include a note explaining what the problem is along with your phone number. Please specify when you need the product back. If you need it back immediately mark the outside of the box "RUSH REPAIR," and Auto Meter will service product within two days after receiving it. (\$10.00 charge will be added to the cost of "RUSH REPAIR.") If you are sending product back for Warranty adjustment, you must include a copy (or original) of your sales receipt from the place of purchase.

12 MONTH LIMITED WARRANTY

Auto Meter Products, Inc. warrants to the consumer that all Auto Meter High Performance products will be free from defects in material and workmanship for a period of twelve (12) months from date of the original purchase. Products that fail within this 12 month warranty period will be repaired or replaced at Auto Meter's option to the consumer, when it is determined by Auto Meter Products, Inc. that the product failed due to defects in material or workmanship. This warranty is limited to the repair or replacement of parts in the Auto Meter instruments. In no event shall this warranty exceed the original purchase price of the Auto Meter instruments nor shall Auto Meter Products, Inc. be responsible for special, incidental or consequential damages or costs incurred due to the failure of this product. Warranty claims to Auto Meter must be transportation prepaid and accompanied with dated proof of purchase. This warranty applies only to the original purchaser of product and is non-transferable. All implied warranties shall be limited in duration to the said 12 month warranty period. Breaking the instrument seal, improper use or installation, accident, water damage, abuse, unauthorized repairs or alterations voids this warranty. Auto Meter Products, Inc. disclaims any liability for consequential damages due to breach of any written or implied warranty on all products manufactured by Auto Meter.

FOR SERVICE CONTACT: AUTO METER PRODUCTS Inc. 413 W. Elm St., Sycamore, IL 60178 USA (815) 895-8141 or
Email us at procycle@autometer.com